

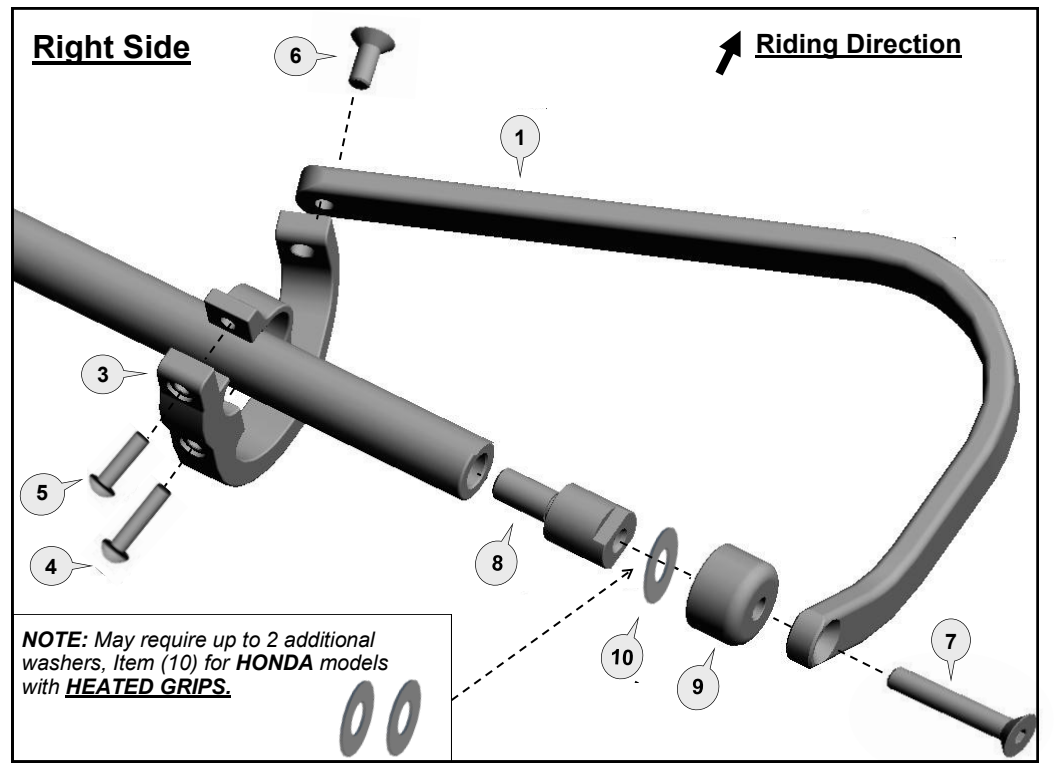

FITTING INSTRUCTIONS for... HONDA CRF 1000L AFRICA TWIN -DCT ('16 on)
HONDA CRF 1000L AFRICA TWIN -non DCT ('16 on)

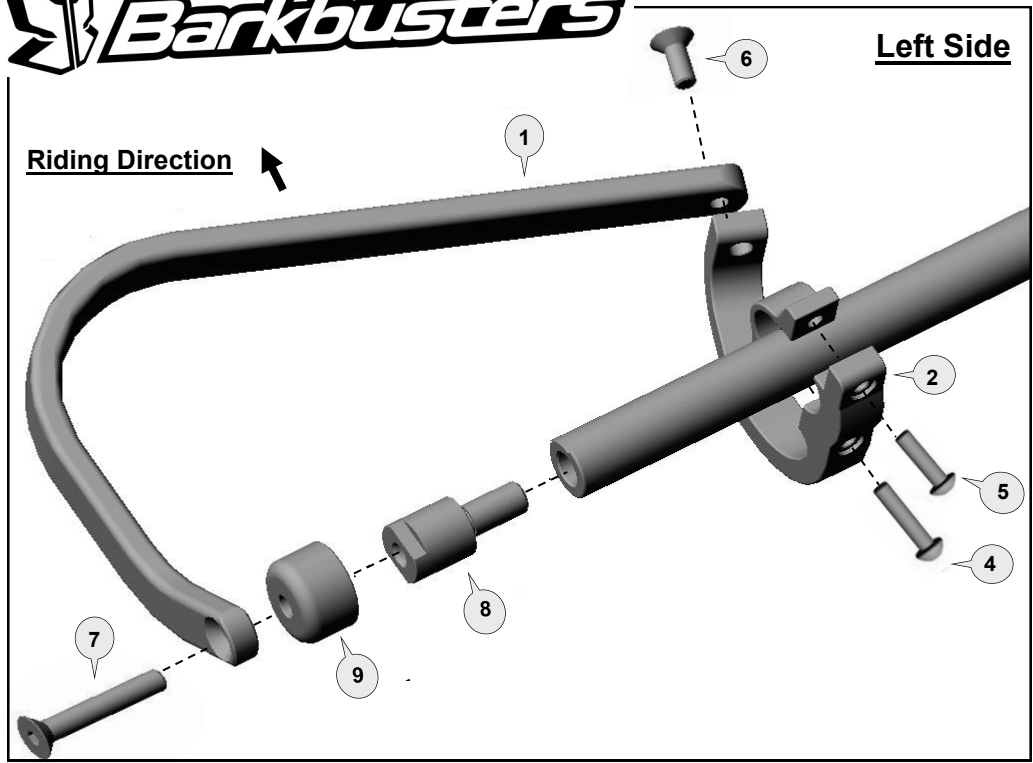

Preparation

- Remove original factory handguard components if installed. Reattach the original screws with the flanged spaces and nuts to the handlebar. Tighten the original screws to the manufacturer's specified torque.
- Remove original external handlebar end weights and metal clips. **NOTE:** Retain internal handlebar weights.

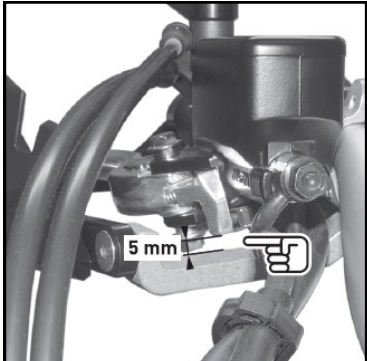

IMPORTANT: Right Side clearance of 5mm required .

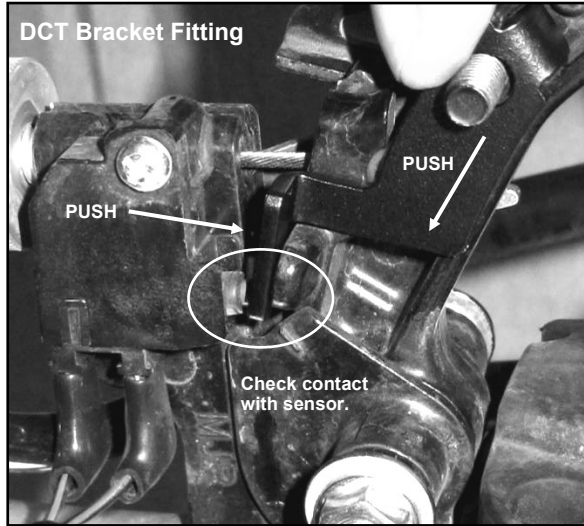

Fitting Procedure

1. Fit Threaded Insert (8) and tighten to specified torque setting.
 2. Loosely assemble clamp (2/3) to handlebar and attach backbone with applicable parts as per diagram. Washer (10) on the **RIGHT** side only, between the Threaded Insert (8) and Bar End Weight (9).
- Note:** The preferred backbone position is horizontal when viewed from side.
3. Tighten all bolts in the following order (7), (6), (4) then (5). Use recommended torque specifications over page.

DCT model ONLY:

1. Loosen park brake cable adjuster a few turns.
2. Remove original screw from the park brake lock and replace with screw (11) then tighten as specified.
3. Mount Pressed Metal Bracket (12) between the brake lever and parking brake sensor and secure with Nut (13) as shown, then tighten as specified.
4. Set brake cable adjuster to desired position and secure.

IMPORTANT: Position bracket (12) as shown in picture before tightening.
← see image

Check the bracket makes contact with the sensor. Slight repositioning of the sensor may also be necessary.

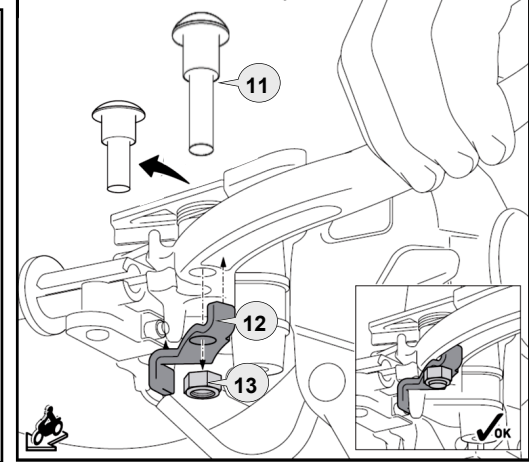

1 Aluminium Bar



PN: BAR-V-036
Pcs. 2 (L & R)

2 Clamp Frame & Saddle (left)



PN: CFS-ADV-L
Pcs. 1

3 Clamp Frame & Saddle (right)



PN: CFS-ADV-R
Pcs. 1

4 Button Head Bolt 30mm



PN: M6x30BHCSZP
Pcs. 2

5 Button Head Bolt 20mm



PN: M6x20BHCSZP
Pcs. 2

6 Flat Head Bolt 20mm



PN: M8x20FHCSZP
Pcs. 2

7 Flat Head Bolt 40mm



PN: M8x40FHCSZP
Pcs. 2

8 Threaded Insert



PN: BESF4
Pcs. 2

9 Bar End Weight



PN: BEW35
Pcs. 2

10 M8 Flat Washer



PN: M8FW
Pcs. 3

11 Shoulder Bolt 30mm



PN: M6x30SB
Pcs. 1

12 Pressed Metal Bracket



PN: BPM1
Pcs. 1

13 Nylock Nut 6mm



PN: M6LN
Pcs. 1

Personalise Your Protection
Guard options sold separately

JET JET-003
VPS VPS-003
Storm STM-003
CARBON BCF-003

Recommended Torque Settings	
M6	10 Nm (7.4 lbf ft)
M8	20 Nm (14.8 lbf ft)
M18 (item 8)	21Nm (15.5 lbf ft)

NOTE:
Part Numbers 11, 12 & 13 ONLY required for DCT models.

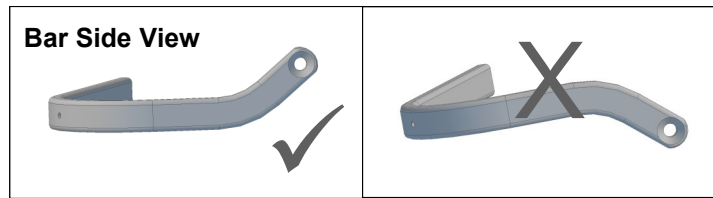

CAUTION:
Installation of the handguard is safety-relevant work and can be complicated. We recommend the installation be performed by a motorcycle service technician. Rideworx accepts no liability for damages caused by improper mounting. All screws, bolts and nuts, including all replacement hardware provided by Rideworx, should be tightened to the torque specified in the table. After the first 50km of riding check all screws, bolts and nuts are tightened to the correct torque. We recommend a medium strength liquid thread lock product on all fasteners.

WARNING:
Check operation of all handlebar controls, specifically the throttle, front brake, kill switch and clutch to ensure they are operating correctly and are in accordance with the OEM specifications. Do not ride the motorcycle if any controls are not operating correctly or if rear view mirror vision is obscured. Check periodically that all bolts are tight.

Disclaimer:
A failure to follow these fitting instructions could cause serious injury, death or property damage. These handguards are intended solely for use with motorcycles/ATV/snowmobiles/scooters that have not been modified. They are not designed to prevent injury or death while riding or in an accident or crash. The user must ensure that all controls are free of the handguards every time that they ride. By installing and/or using this product you acknowledge that you accept these terms and have followed the fitting instructions.



Phone: +61 (0)2 4271 8244
Email: info@barkbusters.net
Web: www.barkbusters.net

